



GIZMOS

Game by Phil Walker-Harding
2-4 players · 40-50 minutes · Ages 14+



The Great Science Fair approaches! You, the brilliant minds of our generation, will compete to build the most creative and powerful Gizmos in your homemade labs. Can you master the four energies and construct the best combos to bring home the first-place prize?

COMPONENTS



112 GIZMO CARDS

- » 4 Starting Gizmo Cards
- » 36 Level 1 Cards
- » 36 Level 2 Cards
- » 36 Level 3 Cards

1 RULEBOOK

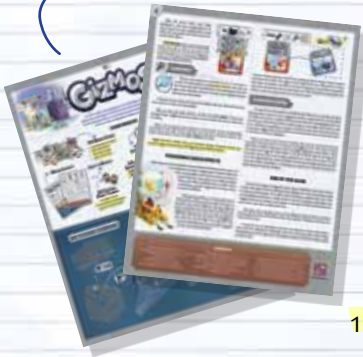

1 LIST OF EFFECTS



20 VICTORY POINT TOKENS

- 14 tokens worth 1 Victory Point and 6 tokens worth 5 Victory Points



4 ENERGY STORAGE RINGS

4 PLAYER DASHBOARDS (1 FIRST PLAYER DASHBOARD)



1 ENERGY DISPENSER

(IN TWO PARTS: PLASTIC BOTTOM AND PAPER TOP)



52 ENERGY SPHERES

- 13 each of Heat (Red), Electric (Yellow), Atomic (Blue), and Battery (Black).

ASSEMBLING YOUR DISPENSER:

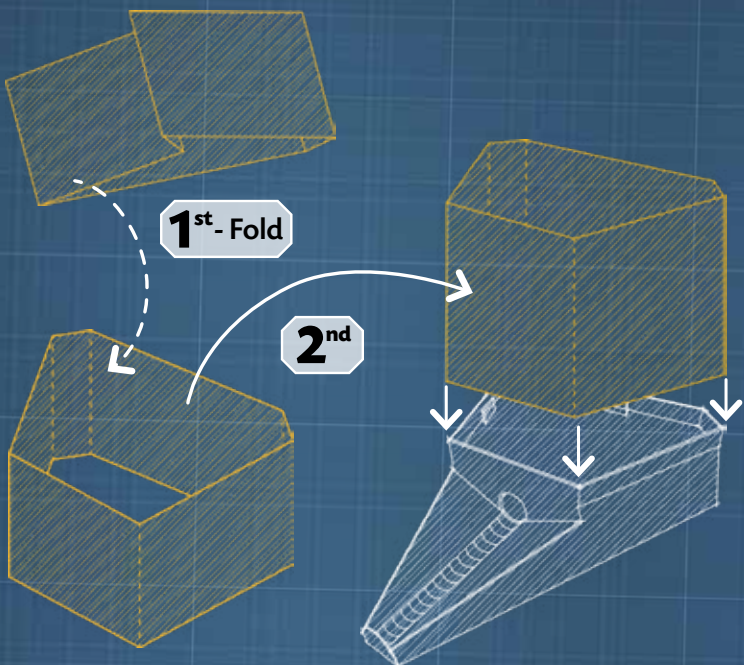

TO STORE THE GAME, KEEP YOUR DISPENSER SEPARATED ON THE BOX

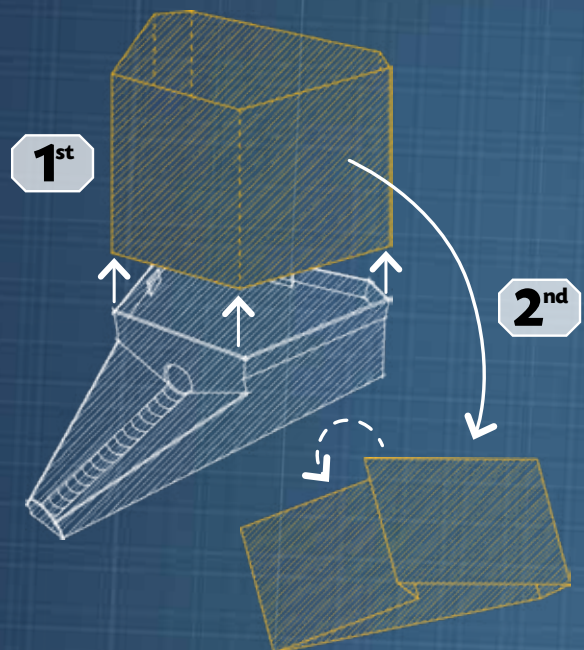

SETUP

- 1) Take a number of Player Dashboards equal to the number of players (the First Player Dashboard must be included). Shuffle them all and randomly give 1 to each player. The player with the First Player Dashboard **G** will be the First Player.
- 2) Each player takes an Energy Storage Ring **A** and their Player Dashboard **B** and places them in front of them.
- 3) Each player takes a Starting Gizmo Card and places it on their Player Dashboard below the File symbol **C**. The area below the Player Dashboard is the Active Gizmo Area.
- 4) Divide the cards into Level Decks (as indicated on the back of the cards) and shuffle each deck separately. For the Level 3 Deck, randomly select 16 cards, and return the rest of the cards to the box.
- 5) Place all three Level Decks in the center of the table next to each other, forming 3 rows. Draw Gizmo cards from each deck according to their Level as follows:
 - » 4 cards for Level 1
 - » 3 cards for Level 2
 - » 2 cards for Level 3

Place each Gizmo Card faceup in the row of the corresponding deck. This will be the Display Area **D**. There will be a total of 9 Gizmo Cards forming a triangle with Level 1 at the bottom.

- 6) Place the Victory Point Tokens near the Gizmo Cards **E**.

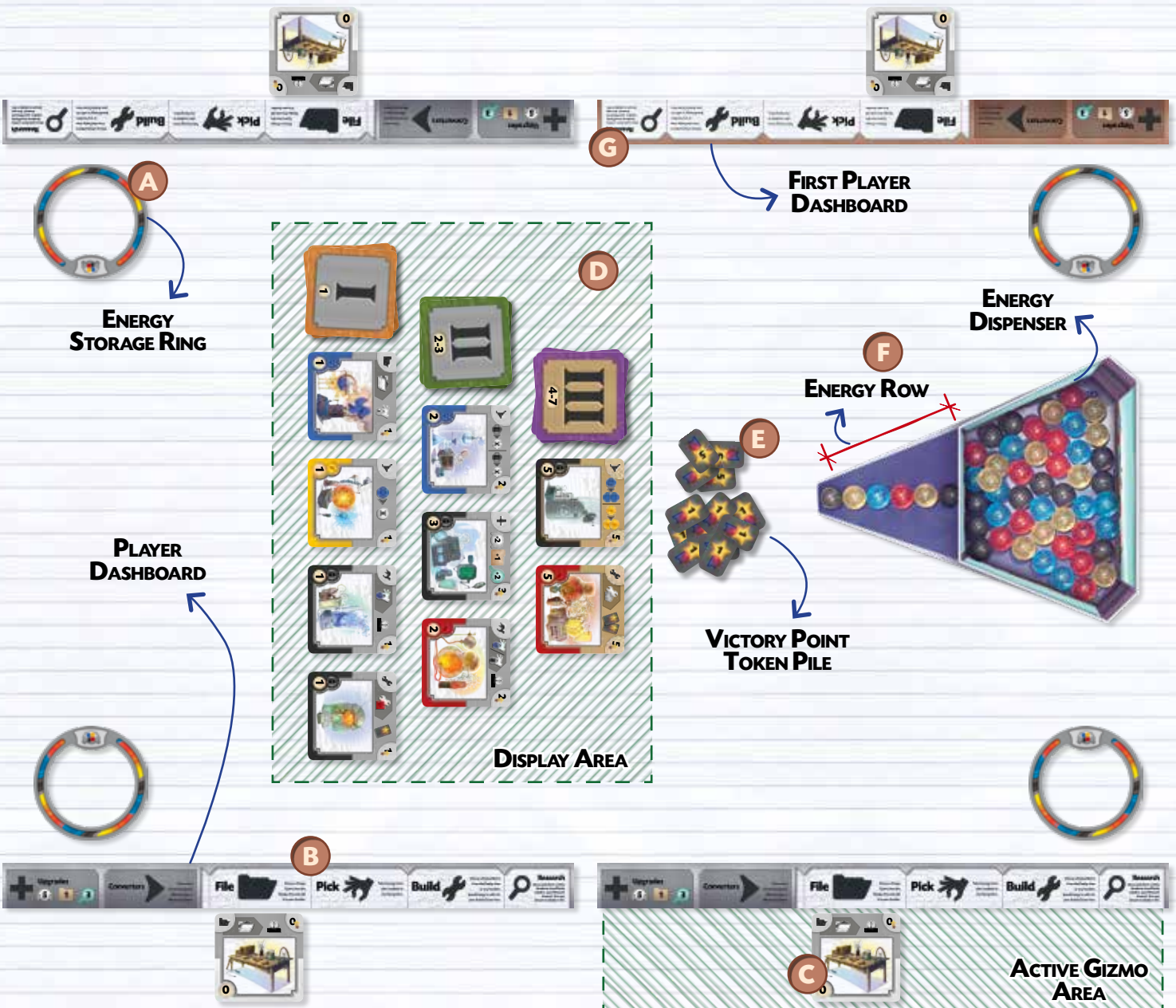

- 7) Assemble the Energy Dispenser by following the "Assembling your Dispenser" instructions on the previous page, and place it within easy reach of all players. Place all 52 Energy Spheres inside it (13 of each color). 6 random Energy Spheres will slide out to for the Energy Row **F**.

Note: If the Energy Spheres aren't falling into the Energy Row, shuffle them inside the dispenser until they do!

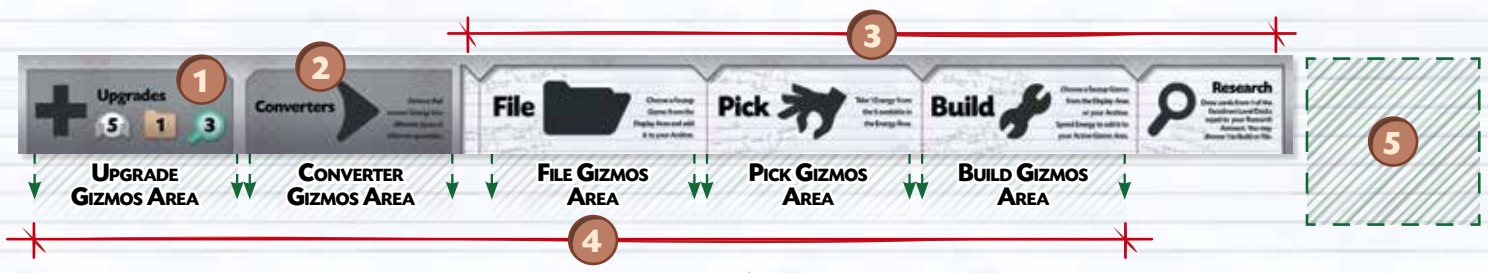

PLAYER DASHBOARD



- 1 This indicates your initial stats (Storage Limit , File Limit , and Research Amount .
- 2 This explains what Converter Gizmos do.
- 3 These are the 4 different actions you can take, along with their explanations.
- 4 These areas below the Player Dashboard are used to keep all Active Gizmos. They are arranged in columns according to their Gizmo Type (see below).
- 5 This area on the side of the Player Dashboard is the Archive, used to hold Gizmos that have been Filed.



GIZMO CARD

- 1 **Gizmo Type:** The type of effect the Gizmo provides and where to place it below the Player Dashboard.
- 2 **Gizmo Effect:** The effect of the Gizmo, including the bonuses it provides and, in some cases, the condition for triggering the effect. (Check the List of Effects for details.)
- 3 **Victory Points:** The amount of Victory Points the Gizmo is worth at the end of the game.
- 4 **Energy Type:** The color of Energy that must be spent to Build this Gizmo.
- 5 **Gizmo Cost:** The quantity of Energy of the indicated Type that must be spent to Build this Gizmo.



THE PLAYER TURN

The First Player takes the first turn, then play moves clockwise. On your turn, you must perform 1 of the following actions:

- » **File:** File 1 Gizmo from the Display Area.
- » **Pick:** Pick 1 Energy of your choice from the Energy Row.
- » **Build:** Build 1 Gizmo from the Display Area or from your Archive.
- » **Research:** Draw Gizmo cards from 1 of the facedown Level Decks and choose 1 to File or Build.

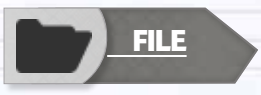

Choose 1 faceup Gizmo card from any row in the Display Area and place it in your Archive, next to your Player Dashboard.

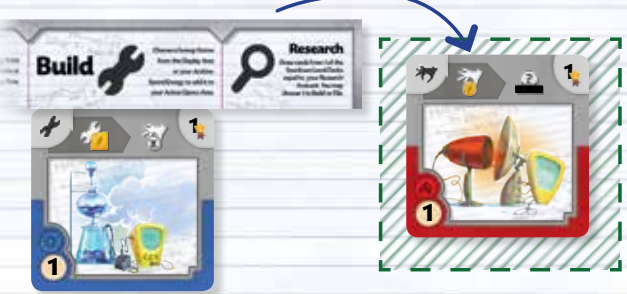

When you take a Gizmo from the Display Area, immediately draw a new Gizmo card from the same Level Deck and place it in the empty slot. After you draw this new Gizmo, your File Action is over.

Your Archive has a limit to how many Gizmos it can hold, as indicated in your Player Dashboard's Upgrades Area. Each player starts the game with a **File Limit of 1**, but some Upgrade Gizmos may



increase that number. Your Archive can never hold more Gizmos than your File Limit, so if you are at your limit, you cannot take a File Action.

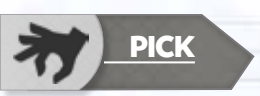

Choose 1 Energy from the 6 available in the Energy Row and add it to your Energy Storage Ring.

Your Energy Storage Ring has a limited amount of Energy it can hold, as indicated in your Player Dashboard's Upgrades Area. Each player starts the game with a **Storage Limit of 5**, but some Upgrade Gizmos may increase that number.



IMPORTANT: Some abilities may let you draw a random Energy (). **This is not a Pick Action.** In those cases, you don't take from the Energy Row. Instead, you draw blindly from the top of the Dispenser.

All Energy taken must go directly to your Energy Storage Ring. Your Ring can never hold more Energy than your Energy Storage Limit, so if you are at your limit, you cannot take any more Energy.



Choose 1 faceup Gizmo card from the Display Area **OR** from your Archive. Spend Energy from your Energy Storage Ring matching the Gizmo's Energy Type and Cost. (To spend Energy, just place them back inside the Energy Dispenser.)



Remember to always replenish the Display Area when you Build a Gizmo from there. After replenishing, your Build action is over.

Example: To build this Gizmo, a player must spend 2 Battery (black) Energy.

Place the Gizmo below your Player Dashboard in the area corresponding to its Gizmo Type. If you have multiple Gizmo cards under the same symbol, stack them so you can see all of their effects.

CONVERTERS: When performing a Build Action, you may be able to use your active Converter Gizmos to convert the Energy you have into the Energy you need. Learn all about Converters in the List of Effects.

RESEARCH



Choose any facedown Level Deck (1, 2, or 3) and draw a number of cards equal to your Research Amount. You may not draw from more than 1 Level Deck at a time. Each player starts the game with a Research Amount of 3, but some Upgrade Gizmos may increase that number.

If there are fewer cards in the chosen Level Deck than your Research Amount, draw only the number of cards available.

After you draw the cards, choose 1 of them and either **Build** it (if you have enough Energy) or **File** it (if you have space in your Archive). Or, you can choose to do neither.

Return the remaining cards facedown to the bottom of the corresponding Level Deck, in the order of your choosing. You may return all drawn cards to the bottom if you wish, or if you can't **File** or **Build** any of them.

Note: The File or Build Action you perform during a Research Action also counts to trigger active Gizmos (see Triggering Gizmo Effects below).

TRIGGERING GIZMO EFFECTS

While taking 1 of the 4 available actions is the basis of the game, the real core of it (and the key to victory) is triggering your Gizmos' effects in order to accomplish much more on your turn than you would otherwise. Every Gizmo you Build and place below your Player Dashboard has an Effect that is activated by a specific Trigger (learn all about these in the List of Effects).

Whenever you perform an action, make sure to check all of the Gizmos you have under that action to see which ones may be triggered. After the triggering action is complete, you may activate the Effects of any triggered Gizmos, in any order you wish. Just keep in mind that each Gizmo may only be used **once** per turn! You may use the Effect of a Gizmo on the same turn it is built, however, it cannot be triggered by the same action that Built it.

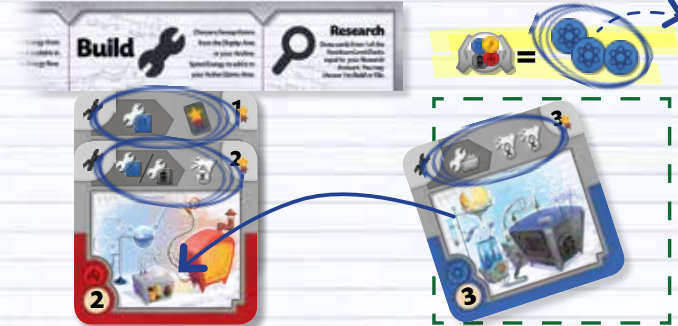
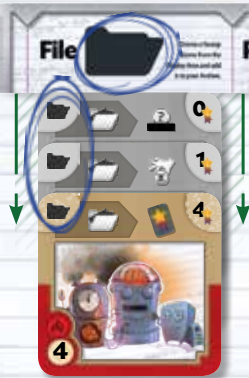
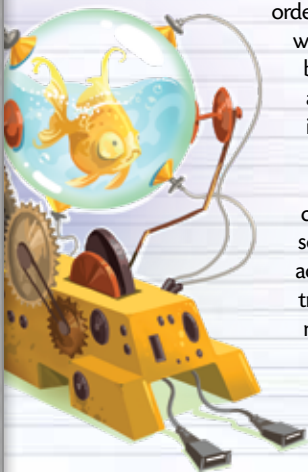

Example: Heather performs a Build Action, spending 3 Atomic Energy to build an Atomic Gizmo from her Archive. This triggers 2 of her Build Gizmos: one that gives her a Victory Point token, and another that allows her to Pick 1 Energy of any type from the Energy Row. Note that, while the Gizmo she just built allows her to Pick 2 Energy when building from the Archive, it cannot be triggered by the action that just built it.

CHAIN REACTIONS

The secret of master inventors is building their Gizmos in a way that will cause chain reactions, with one Gizmo triggering another to generate the most benefits! The Effect of one Gizmo may be a different action than the one originally performed. So, when you then perform that secondary action, it may trigger other Gizmos, and so on. Whenever you perform an action, whether it's your one action for that turn or an action triggered by a Gizmo Effect, always check the Gizmos under that action to see if any of them are triggered.

There is no limit to the number of Gizmos that may be activated, but always remember that each Gizmo can only be used **once** per turn. The order in which each Gizmo's effect is executed is up to the player, regardless of the order in which the actions that triggered those effects occurred. A Gizmo built at the beginning of a chain reaction may end up being activated later in that chain reaction, as long as it's not triggered by the action that Built it. Sometimes finding the optimal order to execute actions and effects can yield greater results. See a detailed example of a chain reaction in the List of Effects.

END OF THE GAME

The end of the game is triggered when a player builds their 4th Level 3 Gizmo or their 16th Gizmo total (including their Starting Gizmo). Once that happens, play continues until the player to the right of the First Player completes their turn. That is, until all players have had an equal number of turns in the game. If the player who triggered the end of the game is the player to the right of the First Player, then the game ends when they complete their turn.

Each player then calculates their score by adding the Victory Points of all their Gizmos, plus any Victory Point Tokens they have acquired. The player with the most Victory Points wins!

In case of a tie, the tied player with the most Gizmos in their Active Gizmo Area wins. If it's still tied, the tied player with the most Energy left in their Energy Storage Ring wins. If it's still tied, the tied player furthest from the First Player, going clockwise, wins.

CREDITS

Game Design: Phil Walker-Harding
Development: Marco Portugal (lead) and Leo Almeida
Game Design Director: Eric M. Lang
Cover Art: Saeed Jalabi
Card Illustrations: Giovana Guimarães,
Hannah Cardoso, and Fernanda Montoni
Graphic Design: Júlia Ferrari and Mathieu Harlaut

Dispenser Design: Júlia Ferrari
Production: Thiago Gonçalves (lead), Patrícia Gil (lead),
Thiago Aranha, Marcela Fabreti, Guilherme Goulart, Isadora
Leite, Aaron Lurie, Renato Sasdelli, Bryan Steele, and Safuan Tay.
Proofreading: Jason Koepp and Colin Young
Publisher: David Preti

Playtesters: Bruno Meira, Caio da Quinta, Daniel
Caballero, Diego de Moraes, Eduardo Cunha Vilela,
Fernanda Ozilak, Fábio Iwace, Fernando Bastos, Flávio
Oota, Gabriel Perin, Gustavo Moreira, João José Gois, Luiz
Alvarez, Luiz Kalagar, Luiza Pirajá, Mário Cioffi, Patricia
Brolezzi, Pedro Oblizner, Ricardo Limonete, Rodrigo Esper,
Rodrigo Sonesso, Rod Mendes, and Vinicius Incorcci



www.cmon.com